

Hubzündung / Drawn-Arc

Gewindebuchse Typ HZ-I / Inner threaded stud type HZ-I

Metrische Innengewindebuchse / Metrical inner threaded studs

HRUSCHKA

BOLZENSCHWEISSTECHNIK - STUD WELDING



Vor dem Schweißen
Before being welded

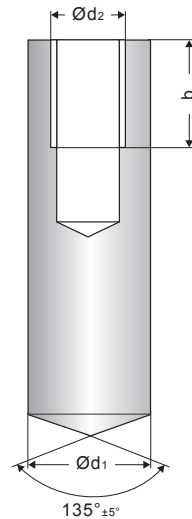

Nach dem Schweißen
After being welded

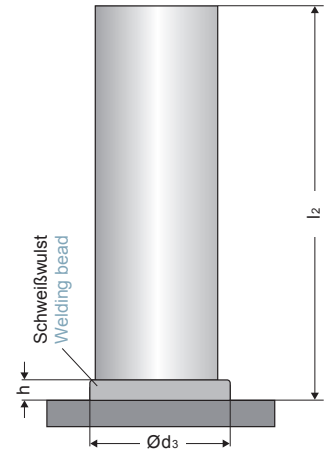

St VA

Alle Angaben in mm / All specifications in mm

d_1	d_2	l_2	d_3	b	h	m^1 (kg) per 1.000
Ø10	M6	12 - 100	13.0	6 - 9	4.0	0.71 - 5.92
Ø12	M8	15 - 200	16.0	8 - 12	5.0	1.14 - 1.30
Ø14.6	M8	30 - 100	18.5	12	5.8	2.32 - 12.83
Ø16	M10	15 - 100	21.0	10 - 15	7.0	2.81 - 5.55

1) Aufgrund der Toleranzen sind die Werte des Gewichtes nur Ungefährwerte. / Due to the tolerances the weight data are only approximated values.